

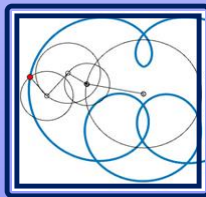

Atomic Clocks as Primary Frequency Sources

WSTS 2026

Online Tutorial Session



Marc A. Weiss, Ph.D.

Marc Weiss Consulting LLC

marcweissconsulting@gmail.com

Three Things to Understand Atomic Clocks

1. Atoms are in discrete energy levels

- a. The change in energy are quanta
- b. Magnetic fields break the levels into the hyperfine structure

2. Energy is proportional to frequency

- a. Einstein discovered the relation: $\Delta E = h\nu$
- b. A change in energy levels, ΔE , is proportional to the frequency ν

3. A clock is a frequency device

- a. A system whose states repeat, e.g. the day
- b. Time is a count of states of frequency, e.g. the calendar

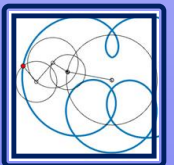

Atomic Frequency Standards: Produce **Frequency** Locked to an Atomic Transition

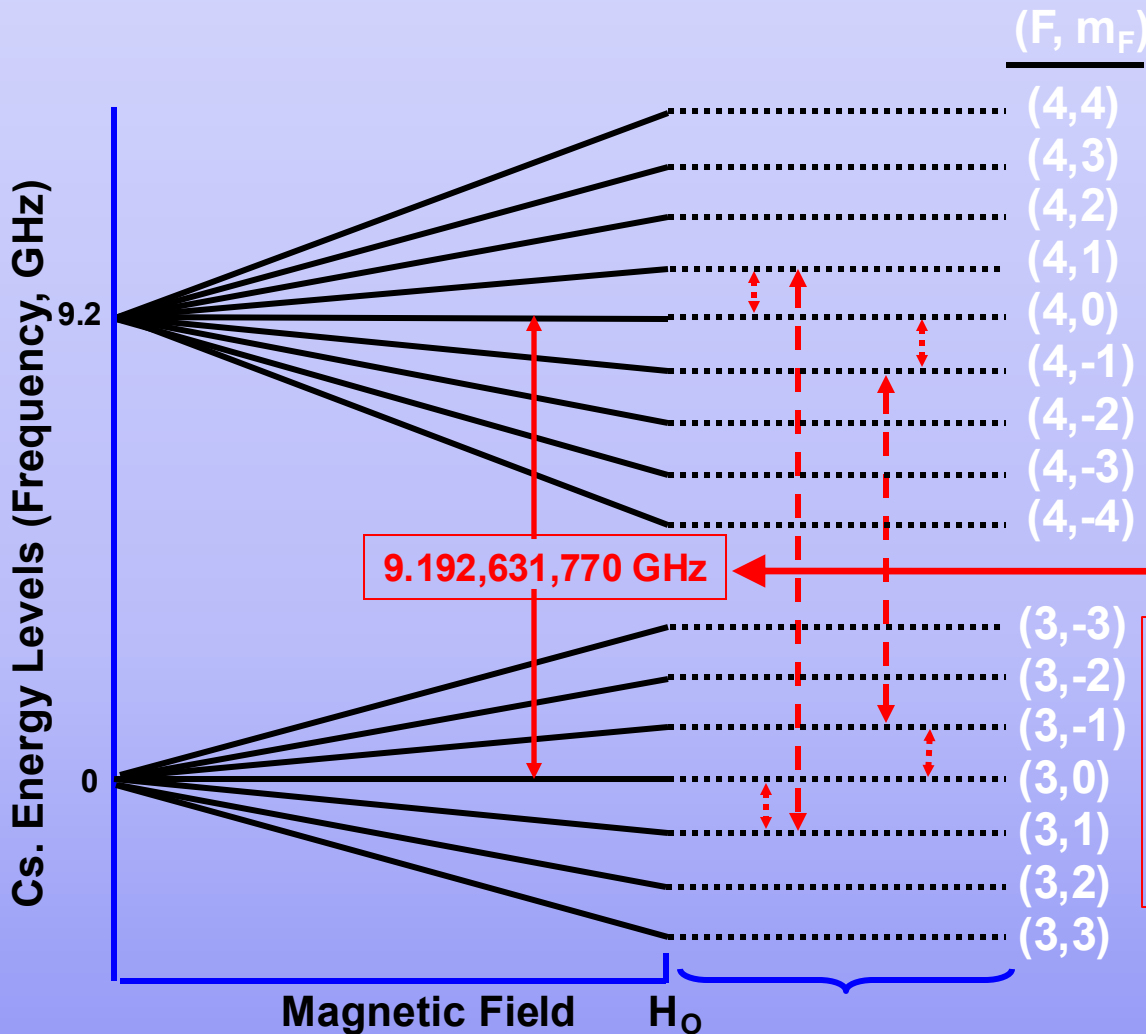

Definition of the second is the definition of **frequency accuracy**: agreement with the Cs clock transition

Absorption of photon at 9,192,631,770Hz results in transition from state (3,0) to state (4,0)
transition from state (3,0) to state (4,0) results in radiation of photon at 9,192,631,770Hz

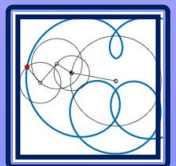

Basic Passive Atomic Clock

1. Obtain atoms to measure
2. Depopulate one hyperfine level
3. Radiate the state-selected sample with frequency ν
4. Measure how many atoms change state
5. Continuously correct ν to maximize measured atoms in changed state

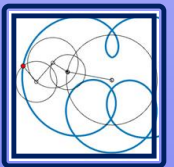

Block Diagram of Atomic Clock Passive Standard

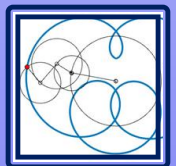
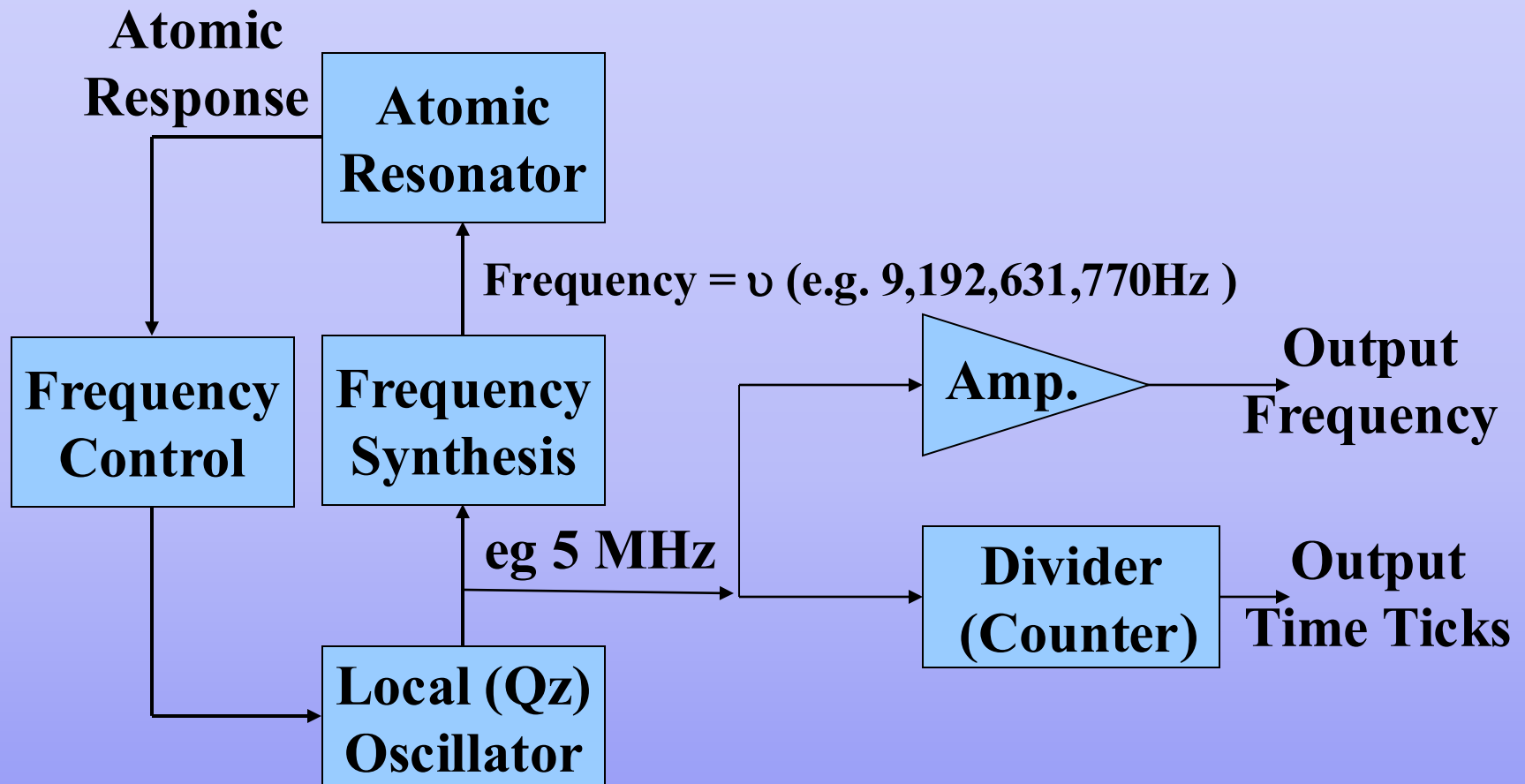

Types of Commercial Atomic Clocks

- Cesium thermal beam standard
 - Best long-term frequency stability
- Rubidium cell standard
 - Small size, low cost
- Hydrogen maser
 - Best stability at 1 to 10 days (short-term stability)
 - Expensive several \$100K
- Chip Scale Atomic Clock (CSAC)
 - Very small size, low power
 - Cs or Rb CSAC not to be confused with Cs beam tube or Rb cell standard
- Note that new clocks are under development!
 - E.g., using atoms cooled to micro-Kelvin
 - Using transitions whose frequency is optical
 - Come to WSTS 2026 for details

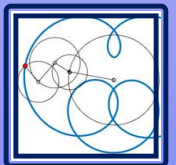

Chip Scale Atomic Clock (CSAC)

- Cs or Rb miniature cell standard – not a Cs beam tube, nor a Rb cell!
- Uses a different way of interrogating atoms: Coherent Population Trapping (CPT)
- Very small size and weight and low power consumption
- Better performance than a quartz oscillator

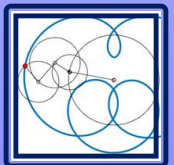

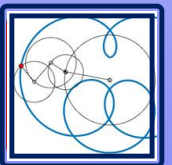
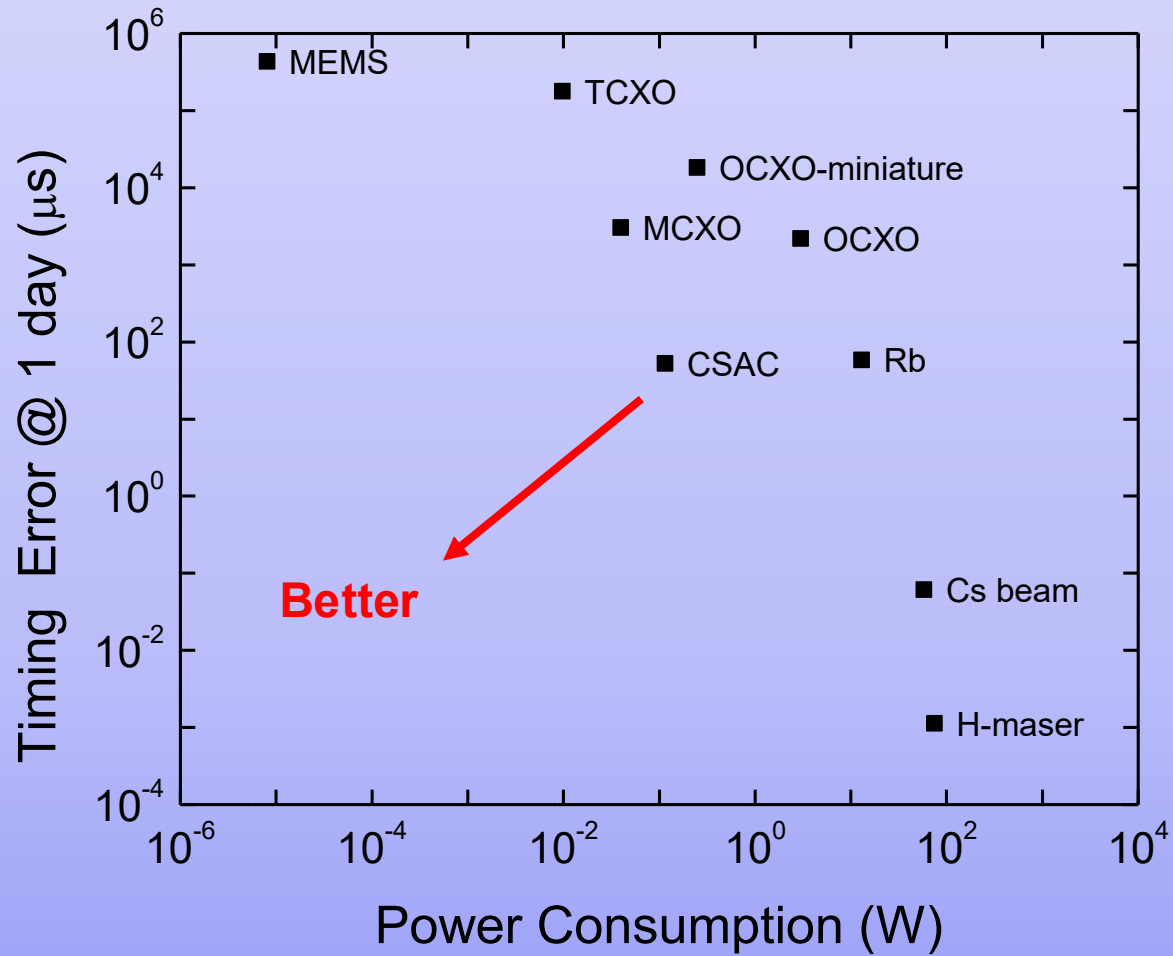

Oscillator Comparison

Technology	Intrinsic Accuracy	Stability (1s)	Stability (floor)	Aging (/day) initial to ultimate	Applications
Inexpensive Quartz, TCXO	10^{-6}	$\sim 10^{-11}$	$\sim 10^{-11}$	10^{-7} to 10^{-8}	Wristwatch, computer, cell phone, household clock/appliance,...
Hi-quality Quartz, OCXO	10^{-8}	$\sim 10^{-12}$	$\sim 10^{-12}$	10^{-9} to 10^{-11}	Network sync, test equipment, radar, comms, nav,...
CSAC	$\sim 10^{-9}$	$< 10^{-10}$	$< 10^{-11}$	$< 10^{-12}$	Drones, satellites, underwater, network sync, ...
Rb Oscillator	$\sim 10^{-9}$	$\sim 10^{-11}$	$\sim 10^{-13}$	10^{-11} to 10^{-13}	Wireless comms infrastructure, lab equipment, GPS, ...
Cesium Beam	$\sim 10^{-13}$	$\sim 10^{-11}$	$\sim 10^{-14}$	nil	Timekeeping, Navigation, GPS, Science, Wireline comms infrastructure,...
Hydrogen Maser	$\sim 10^{-11}$	$\sim 10^{-13}$	$\sim 10^{-15}$	10^{-15} to 10^{-16}	Timekeeping, Radio astronomy, Science,...

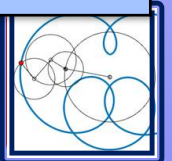

Oscillator Comparison (continued)

Technology	Size	Weight	Power	World Market	Cost
Inexpensive Quartz, TCXO	$\approx 1 \text{ cm}^3$	$\approx 10 \text{ g}$	$\approx 0.010 \text{ W}$	$\approx 10^9\text{s/year}$	$\approx \$30\text{-}50$
Hi-quality Quartz, OCXO	$\approx 50 \text{ cm}^3$	$\approx 500 \text{ g}$	$\approx 10 \text{ W}$	$\approx 10\text{Ks/year}$	$\approx \$100\text{s}$
CSAC	$\approx 17 \text{ cm}^3$	$\approx 35 \text{ g}$	$\approx 0.12 \text{ W}$?	$\approx \$1000\text{s}$
Rb Oscillator	$\approx 200 \text{ cm}^3$	$\approx 500 \text{ g}$	$\approx 10 \text{ W}$	$\approx 10\text{Ks/year}$	$\approx \$1000\text{s}$
Cesium Beam	$\approx 30,000 \text{ cm}^3$	$\approx 20 \text{ kg}$	$\approx 50 \text{ W}$	$\approx 100\text{s/year}$	$\approx \$10\text{Ks}$
Hydrogen Maser	$\approx 1 \text{ m}^3$	$\approx 200 \text{ kg}$	$\approx 100 \text{ W}$	$\approx 10\text{s/year}$	$\approx \$100\text{Ks}$

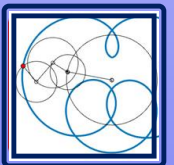

Holding a Microsecond after Loss of Sync

	Temperature Compensated Crystal Oscillator (TCXO)	Oven Controlled Crystal Oscillator (OCXO)	Chip Scale Atomic Clock (CSAC)	Rb Oscillator	Cs Beam-Tube Oscillator
Range of times to hold a microsecond	10 minutes – 1 hour	1 – 24 hours	3-15 hours	8 hours – 3 days	10-300 days
Cost Range	\$5-20	\$50-500	\$1.5K-3K	\$500-1500	\$20K - \$50K

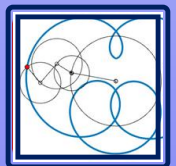

Conclusions: Atomic Standards

- Classic (over decades) commercial atomic clocks are Cs. beam tubes, Rb. Cells, and H-masers, with more recently CSACs
- These atomic frequency standards share a common theme: the stabilization of an electronic (quartz) oscillator with respect to an atomic resonance.
- Although the use of atoms brings with it new quantum mechanical problems, the resulting long-term stability is unmatched by traditional classical oscillators.
- Revolutionary new atomic frequency standards are in development as commercial devices

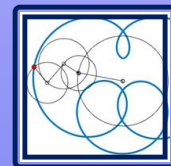

Thanks for your attention!

