

Time Holdover and Oscillator Requirements

WSTS 2014



Telecommunications



Global Positioning



Space



Defense

Oscillators

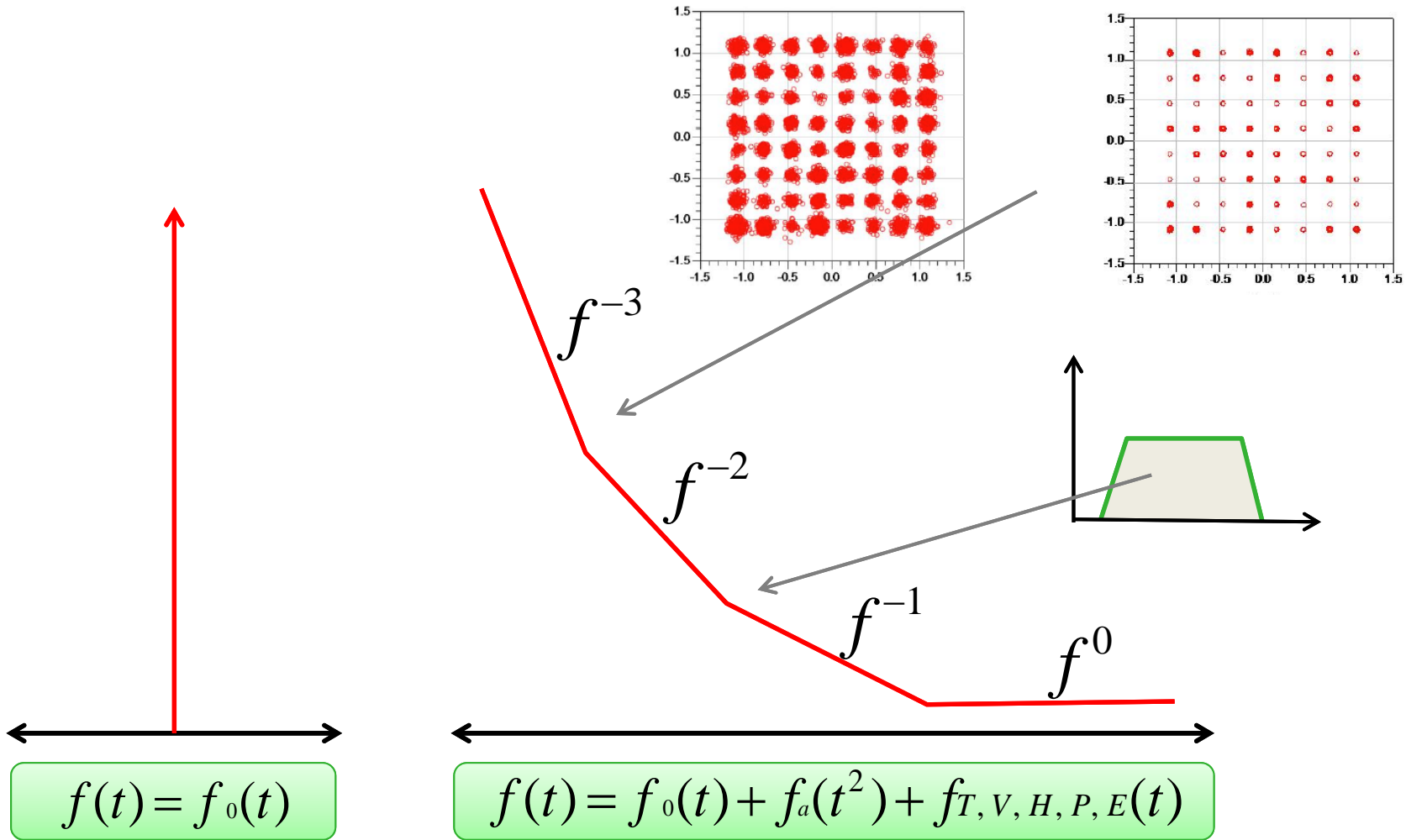



Construction

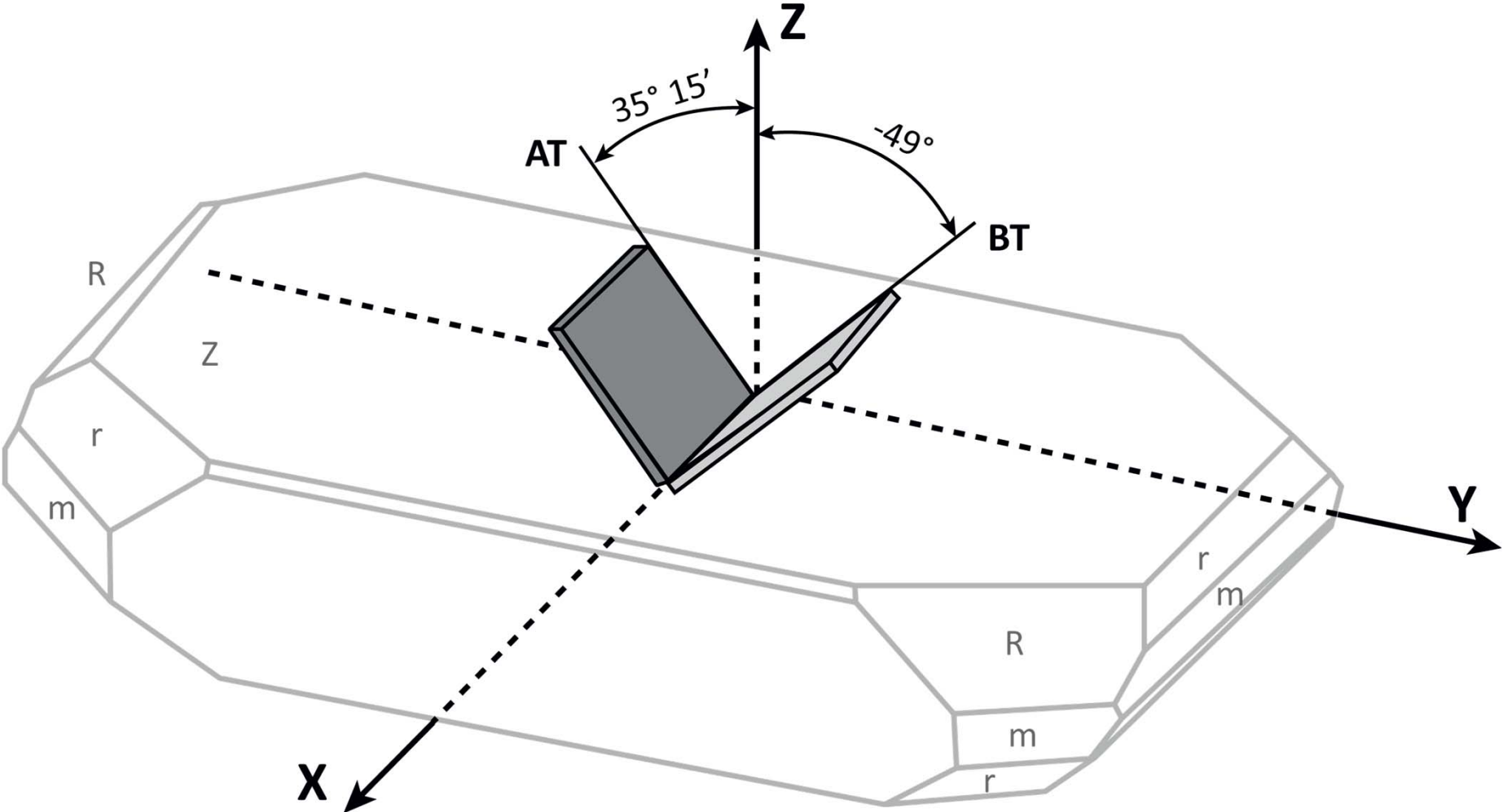



Construction

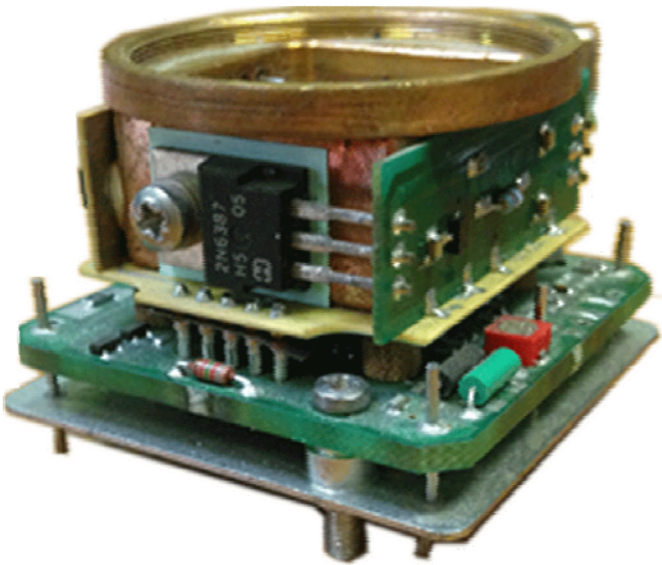
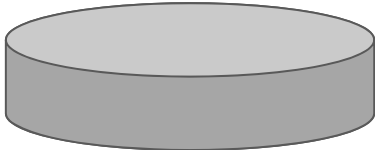
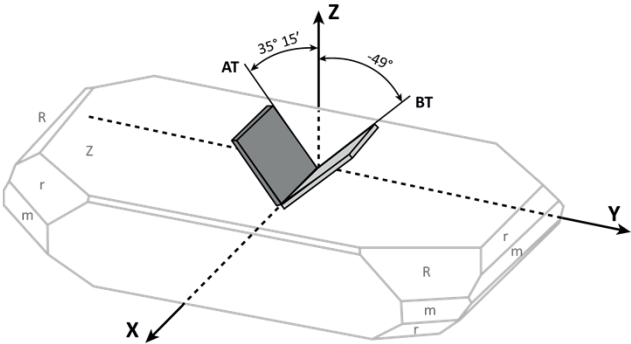

Oven Control

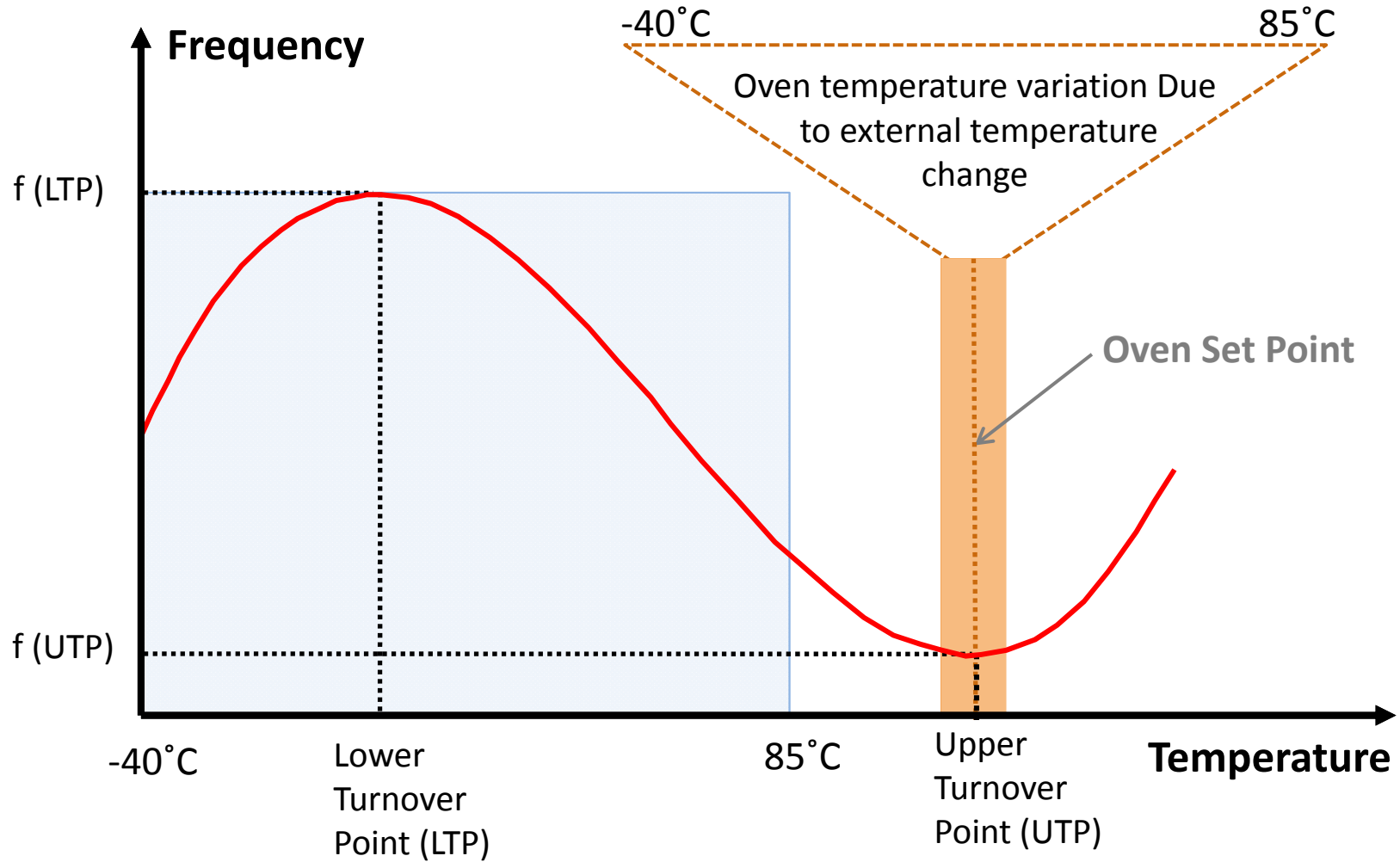

Impairments



Storage Impact on Oscillators

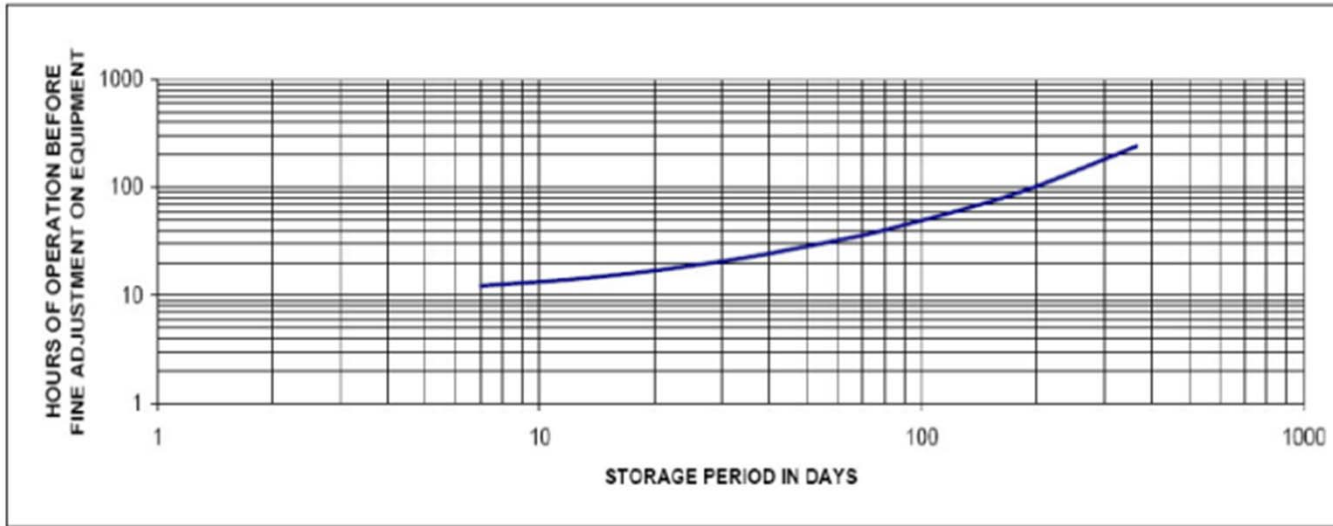

Reflow Impact on Oscillators

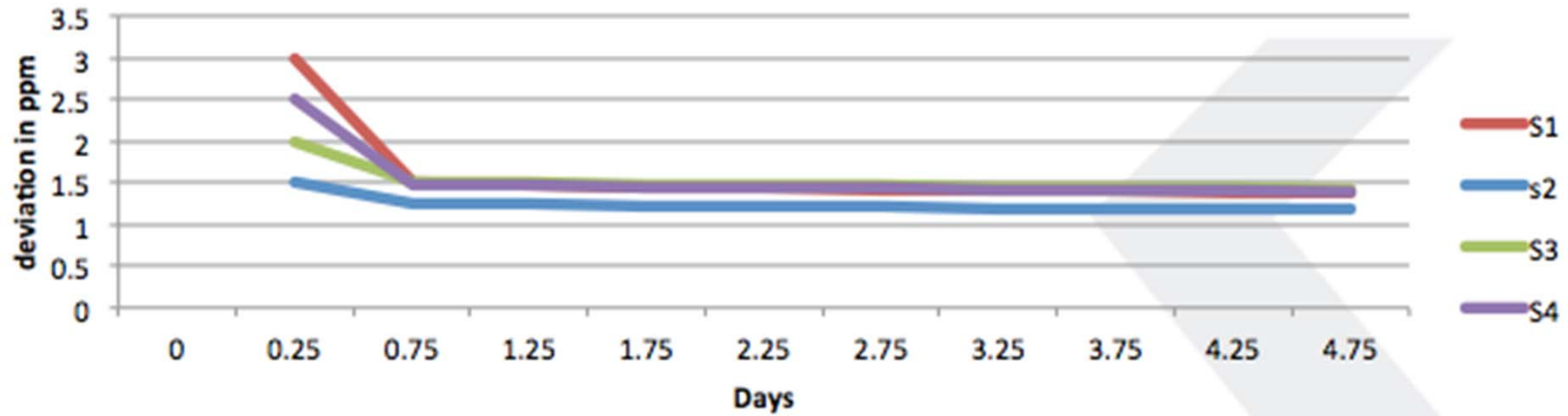

Impairments



Aging effect on Oscillators

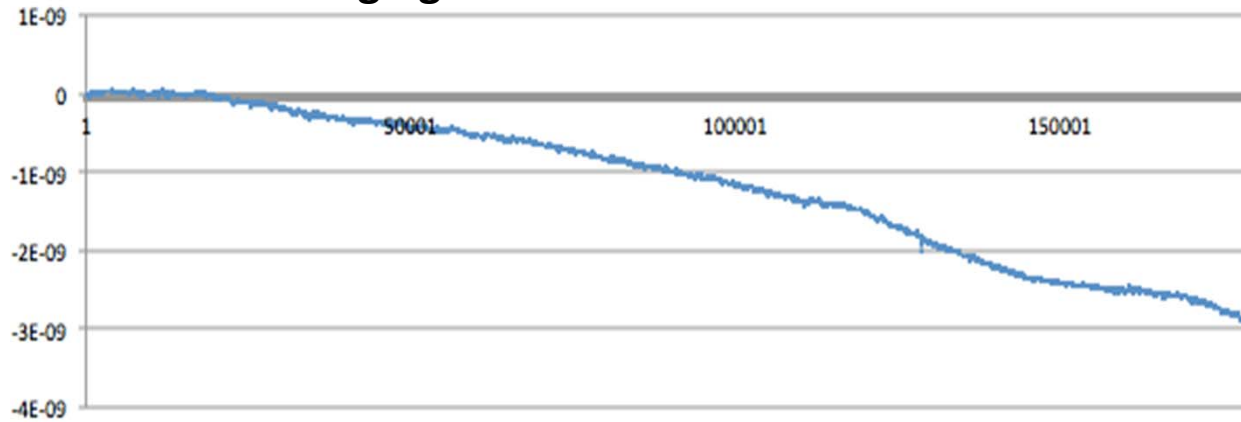

Temperature Effect on Oscillators

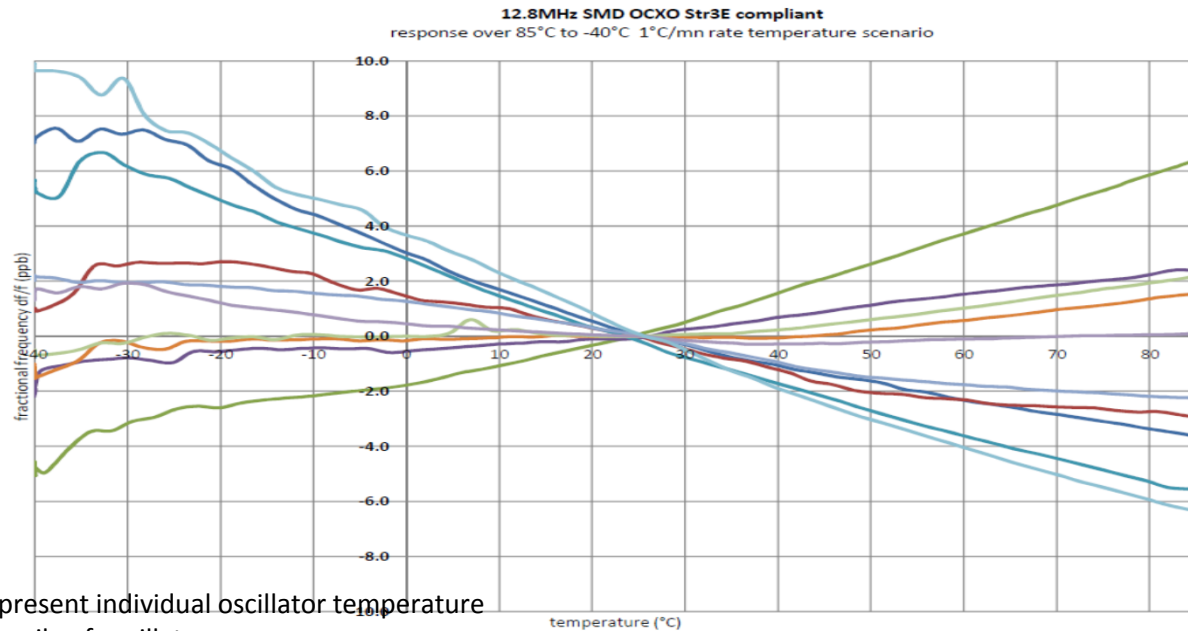

The different colours represent individual oscillator temperature behaviour in the same family of oscillators

Impairments



Hysteresis effect on Oscillators

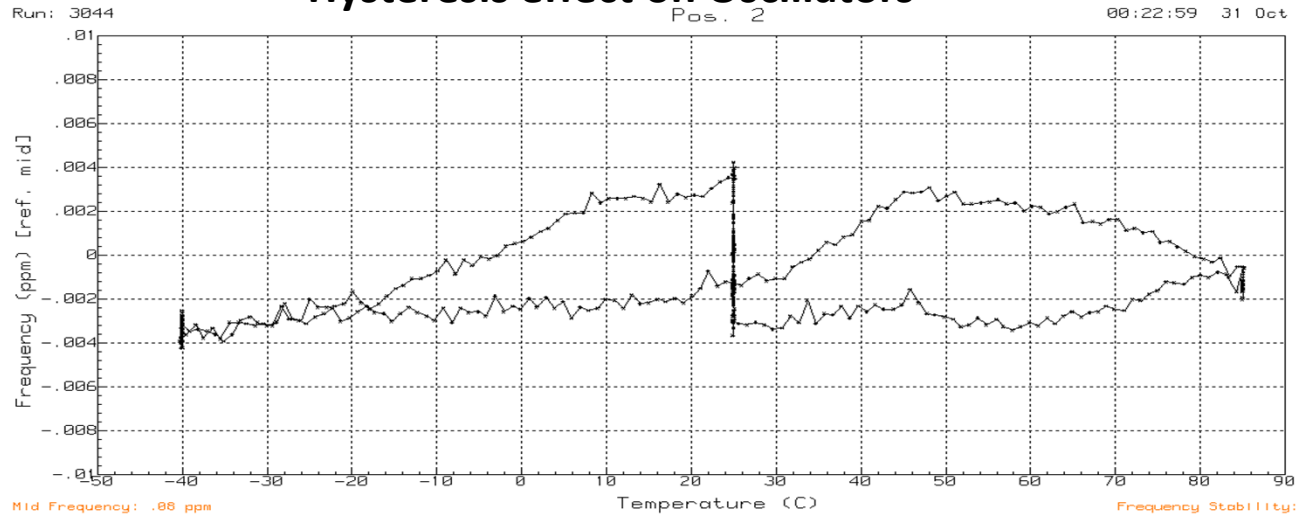

Retrace effect on Oscillators

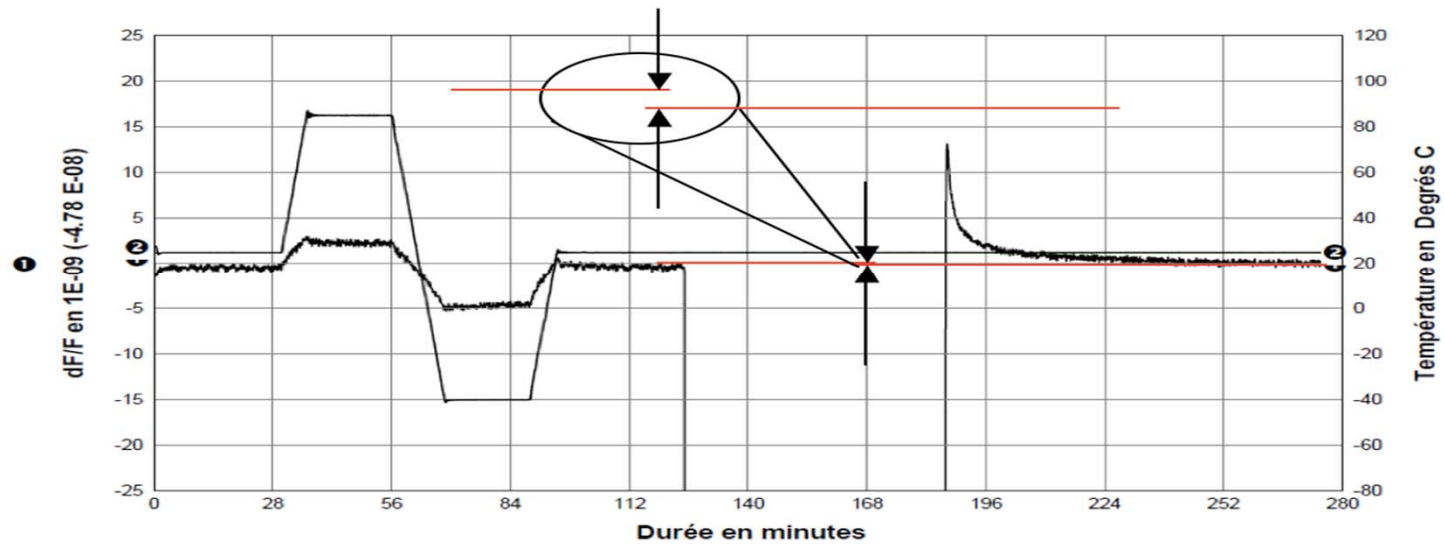



Impact of Oscillator on a Loop

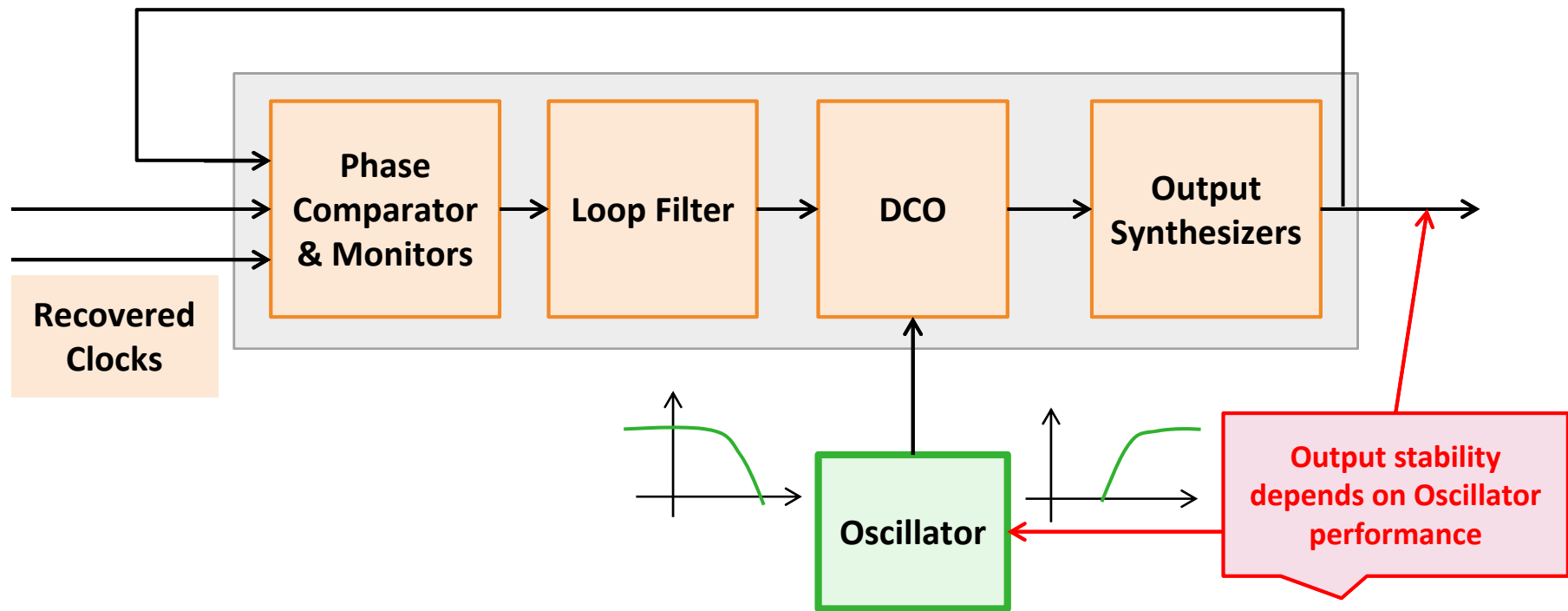



Holdover Operation

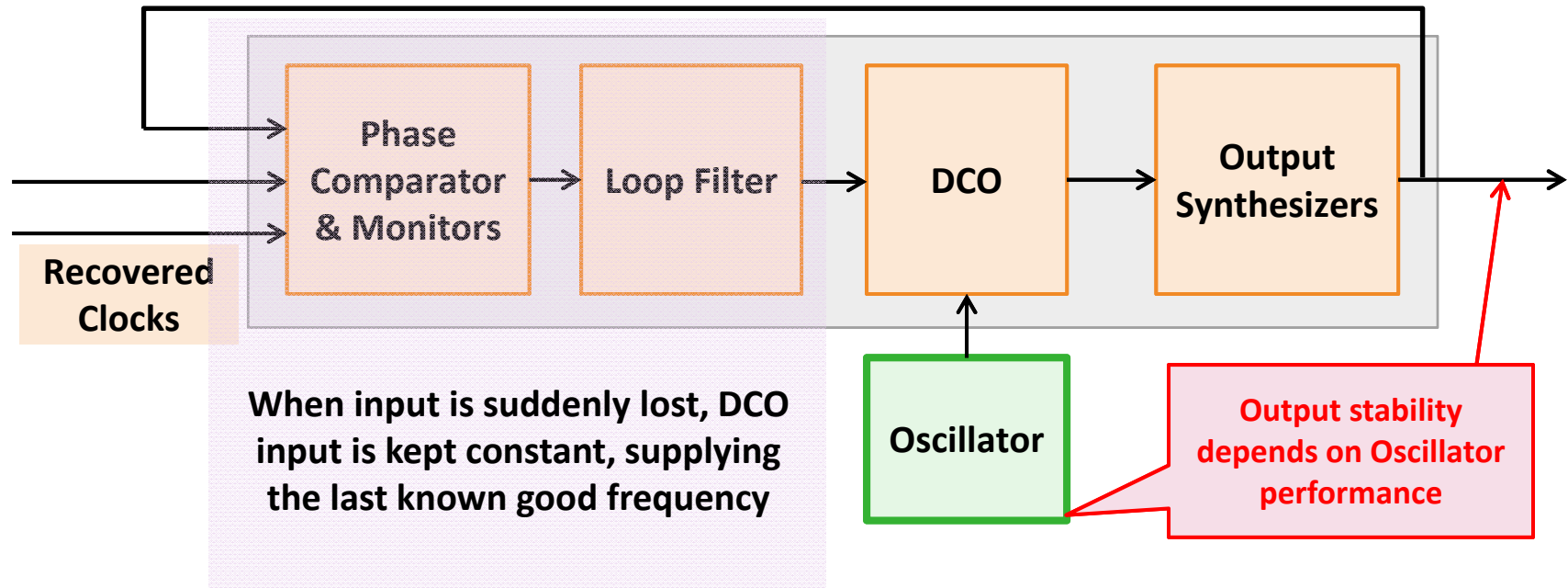

➤ Example

Initial holdover accuracy	±50 ppb	Best case system accuracy
Initial phase jump	± 120 ns	Occurs because of entry to holdover
Oscillator temperature stability	± 2 ppm	Usually -40 to +85 °C
Oscillator Aging	± 100 ppb/24hrs	
Other effects (Vss, load, etc.)	± 100 ppb/24hrs	



Application Requirements

- 1.5us requirement for LTE TDD base stations
- <0.5us for LTE-A and positioning applications
- GNSS based systems are vulnerable
- GNSS failure situations of 72 hours envisioned
- 1.5us for 24 hours translates to stability of $3e-11$!

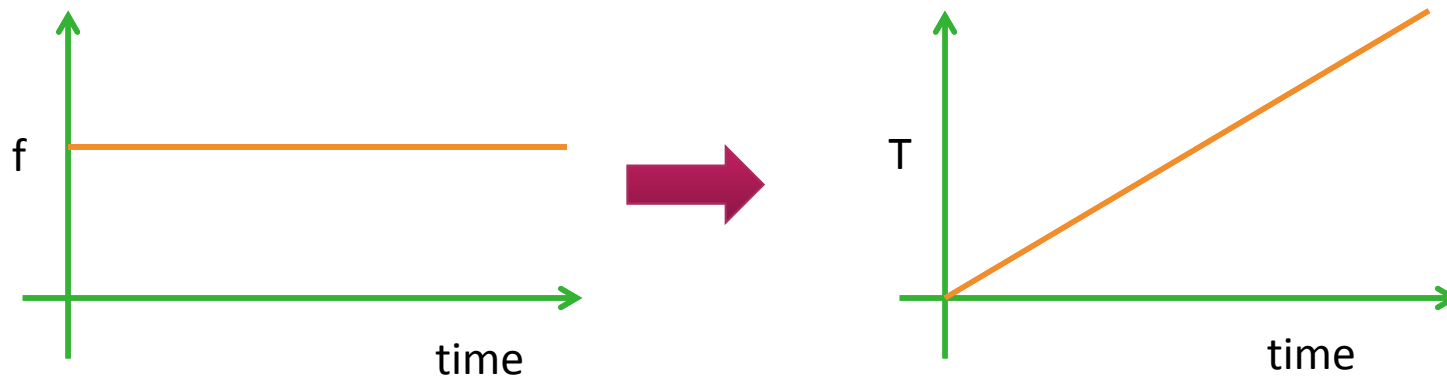

Improving holdover => Improving Stability



- **Crystal related improvements**
- **Mechanical improvements**
- **Using System Supports**
- **Enhancing Control loops and Electronics**
- **Other Environmental effect related Controls**



Crystal & Mechanical Enhancements

- Crystal enhancements

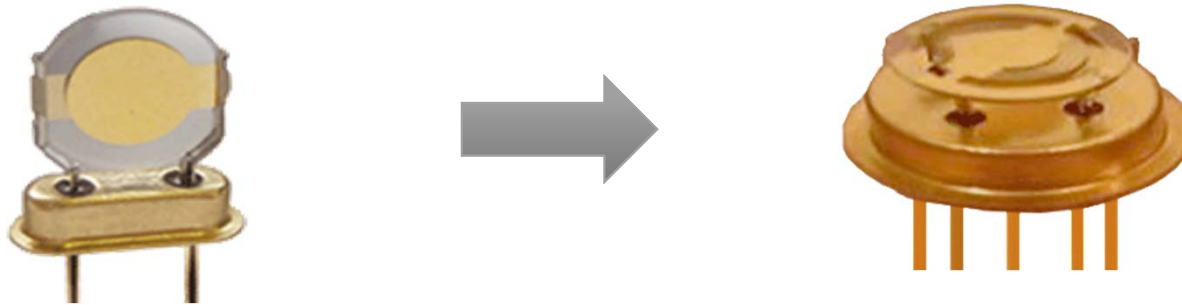

- Improving Mechanical Structures

- Thermal isolation improvements



Compensation & Enhancements

- Aging control
- Thermal self control
- Hysteresis Control
- Supply Voltage variation control
- Temperature effects of Frequency variation control



Control Enhancements

- **Fine granularities for controls**
- **Precise sensor requirements**
- **Higher order prediction algorithms**
- **Phase noise impact with active components**



System Effects

- **Reducing effects due to gravity, vibration & shock**
- **Minimizing radiation effects**
- **Resisting environmental effects – Humidity & Pressure**





Testing Challenges

- **Measured aging on individual oscillators**
- **Zero Gap testing**
- **Improvements for production benches**
 - ❑ Measurement accuracy
 - ❑ Continuous measurements
- **Temperature profiles for testing**





Temperature Testing of Sync

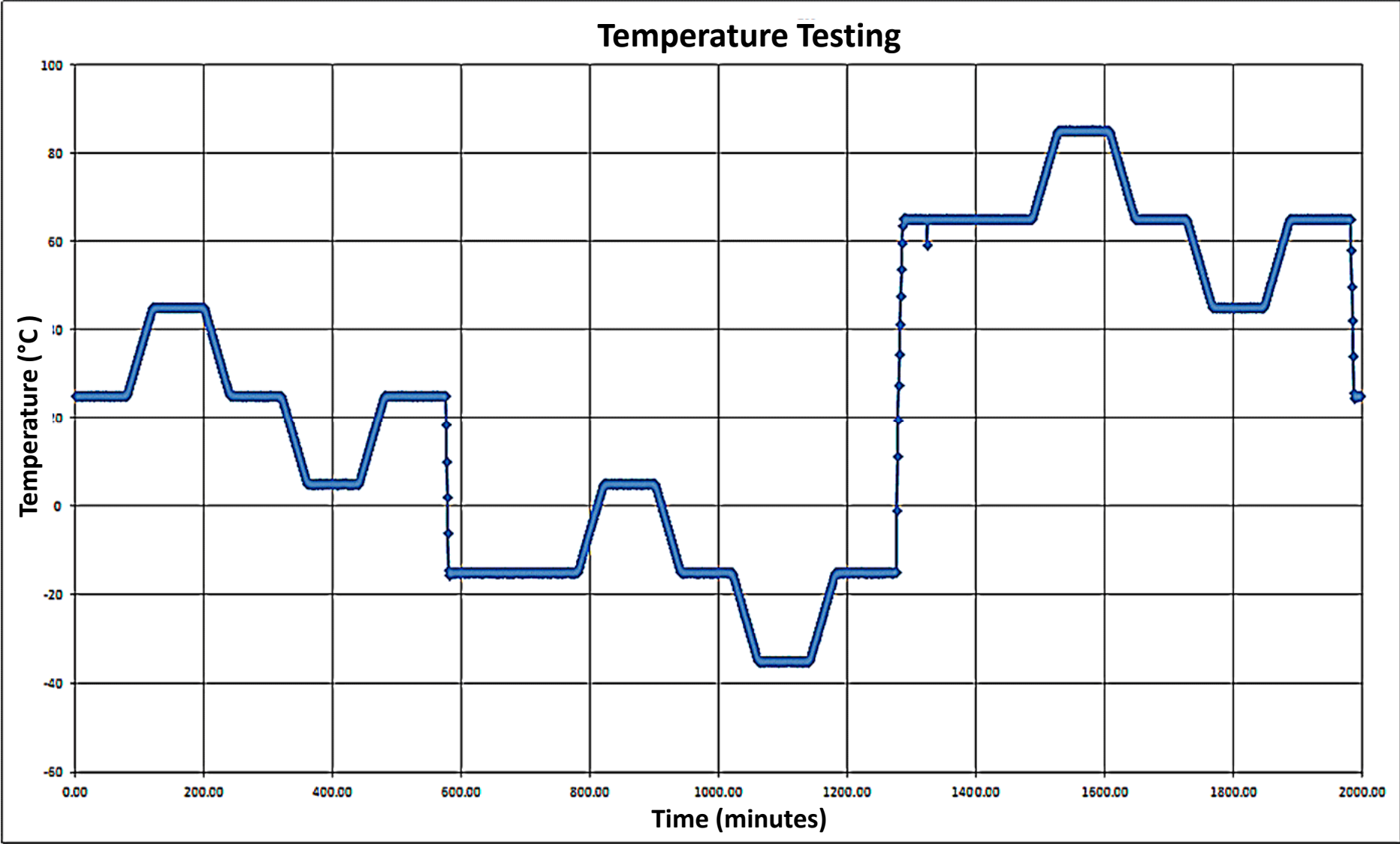

Sample Performances

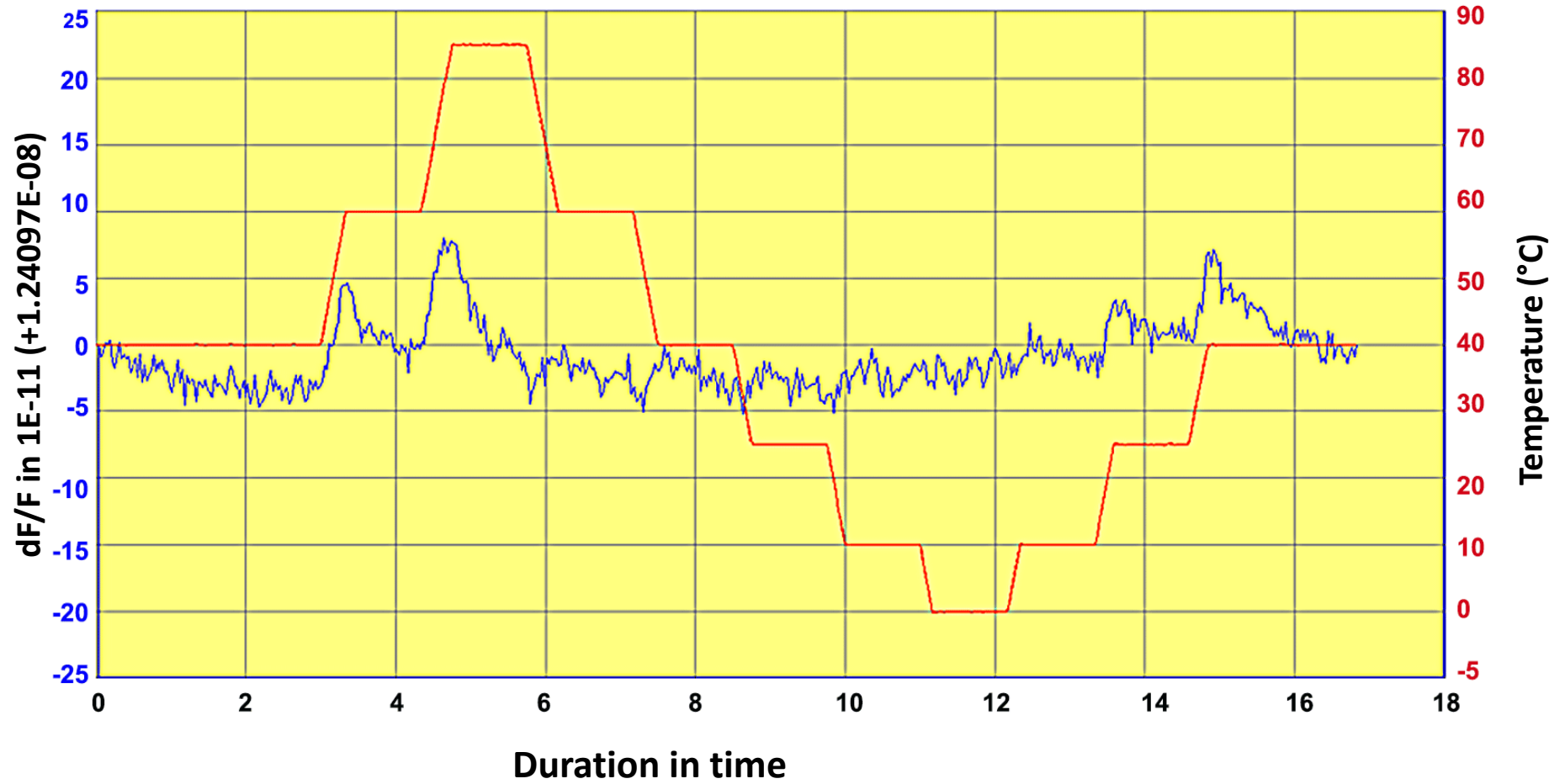



Summary

- Long term time holdover is desired but challenging
- Crystal based oscillators - Hurdles in compensation
- High stability oscillators pose testing challenges





References

- Contributions of Dr. Nigel Hardy, Vincent Candelier, Cyril Datan, Principle R & D Engineers at Rakon
- Various ITU-T documents
- Various documents published by NIST
- J.R Vig; Quartz Crystal Resonators and oscillators for frequency control and timing applications



rakon
synchronising connectivity

