



**Integrated Device Technology**

---

# Synchronization Standards

Silvana Rodrigues, System Engineering, IDT , [silvana.rodrigues@idt.com](mailto:silvana.rodrigues@idt.com)

Tutorial - WSTS 2015

March 9, 2015 – San Jose - CA

# Agenda

- Standard Bodies
- ITU-T Frequency Profile
- ITU-T Time/phase Profiles
- IEEE 1588
- North America Standards (SONET/PDH)G.8272
- Summary

# Synchronization Standards Bodies

- ITU-T (International Telecommunication Union – Telecom Sector), Study Group 15, question 13 Network synchronization and time distribution performance
  - Frequency, time and phase profiles for IEEE 1588
  - Network and equipment synchronization requirements
  - Test and measurement instrumentation
- IEEE (Institute of Electrical and Electronics Engineers)
  - IEEE 1588
  - IEEE 802.1AS, IEEE 802.1ASbt
  - C37.238 (Power profile)
- ATIS (Alliance for Telecommunications Industry Solutions) COAST-SYNC (Copper/Optical Access, Synchronization and Transport)
- IETF (Internet Engineering Task Force)
  - TICTOC (Timing over IP Connection and Transfer of Clock)
- There are other SDOs that define synchronization aspects for their specific needs, e.g.:
  - 3GPP defines synchronization requirements with particular focus on the radio interface
  - MEF defines synchronization requirements for Circuit Emulation and for Mobile Backhaul Implementation Agreement



International  
Telecommunication  
Union

# ITU PROFILES

# IEEE-1588 Profiles

- IEEE-1588 defines profile as “The set of allowed Precision Time Protocol (PTP) features applicable to a device”
- “The purpose of a PTP profile is to allow organizations to specify specific selections of attribute values and optional features of PTP that, when using the same transport protocol, inter-work and achieve a performance that meets the requirements of a particular application.”
- A PTP profile should define
  - Best master clock algorithm options
  - Configuration management options
  - Path delay mechanisms (peer delay or delay request-response)
  - The range and default values of all PTP configurable attributes and data set members
  - The transport mechanisms required, permitted, or prohibited
  - The node types required, permitted, or prohibited
  - The options required, permitted, or prohibited

\* IEEE Std 1588-2008 IEEE Standard for a Precision Clock Synchronization Protocol, copyright 2008 IEEE. All right reserved.



International  
Telecommunication  
Union

# ITU-T FREQUENCY PROFILE

# ITU-T G.8265.1 Frequency Profile IEEE-1588 without support from Network

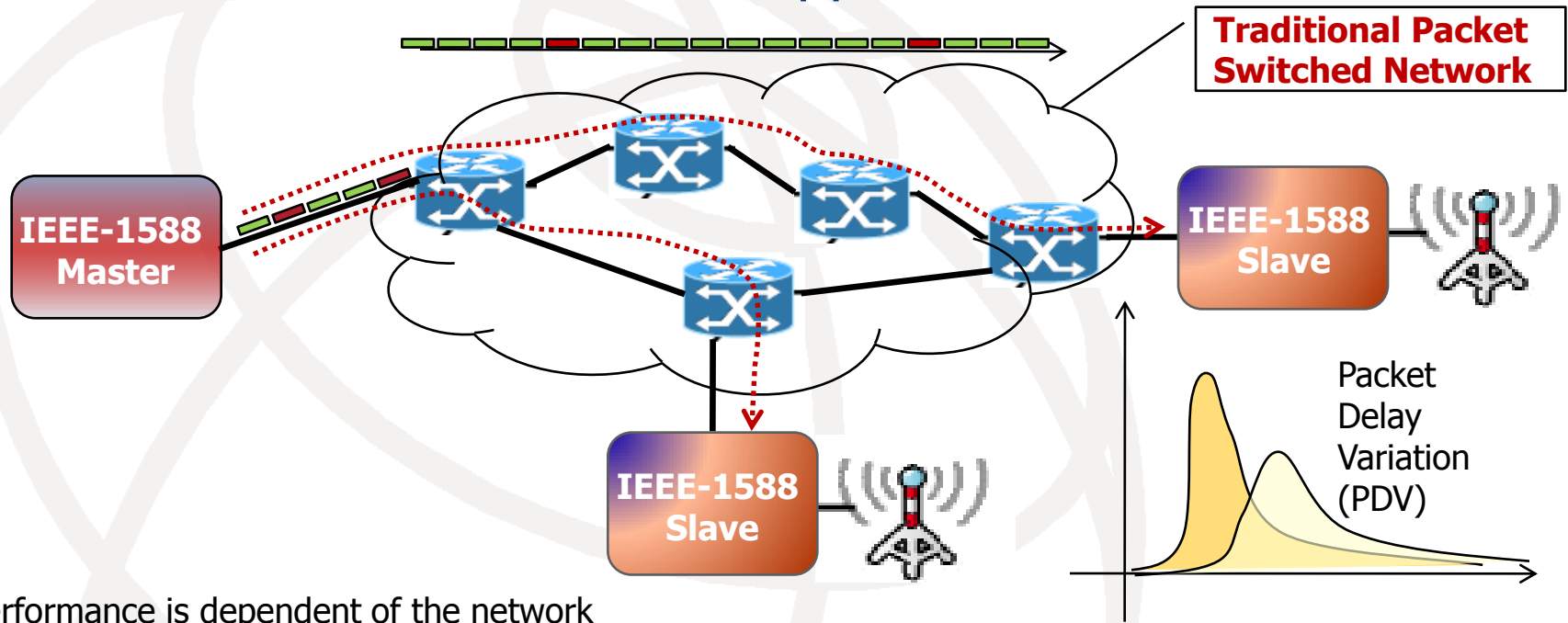

- Performance is dependent of the network
  - The clock recovery algorithm is adaptive in nature, therefore the performance is impacted by packet delay variation in the network
- The quality of the clock delivered to the application depends on several factors
  - The quality of the oscillator at the slave, the packet delay variation of the network, the number of timing packets per second
- ITU-T consented several Recommendations for IEEE-1588 for Frequency Synchronization targeting wireless backhaul applications
  - G.8265 (Architecture and requirements for packet-based frequency delivery), G.8265.1 (Precision time protocol telecom profile for frequency synchronization), G.8263 (Timing Characteristics of Packet based Equipment Clocks (PEC)), G.8261.1 (Packet Delay Variation Network Limits applicable to Packet Based Methods), and G.8260 (definition of PDV metrics)

# G.8265.1 - PTP Options and Configurable Attributes

- One-way versus two-way mode
  - Both one-way and two-way modes are supported in the Frequency Profile
- Unicast versus Multicast mode
  - Only Unicast mode is allowed in the Frequency Profile
  - Unicast Message negotiation is used
- One-step versus two-step clock mode
  - Both one-step and two-step clocks are supported in the Frequency Profile
- PTP mapping
  - IEEE1588-2008 annex D - Transport of PTP over User Datagram Protocol over Internet Protocol Version 4 is supported in the Frequency Profile
  - IEEE1588-2008 annex E - Transport of PTP over User Datagram Protocol over Internet Protocol Version 6 is supported in the Frequency Profile
- PTP Message rates
  - Sync /Follow-up – min rate: 1 packet every 16 seconds, max rate: 128 packets per second
  - Delay\_Request/Delay\_Response – 1 packet every 16 seconds, max rate: 128 packets per second
  - Announce – min rate: 1 packet every 16 seconds, max rate: 8 packets per second, default: 1 packet every 2 seconds
  - Signaling messages – no rate is specified



# G.8265.1 - Alternate BMCA

- The alternate BMCA in G.8265.1 is static, each master is isolated by a separated PTP domain that is done through the unicast communication
  - Grandmasters do not exchange Announce messages.
  - Masters are always active
  - Slaves are always slave-only clocks
- The Master selection process is based on the Quality Level (QL)-enabled mode per ITU-T Recommendation G.781
  - Quality Level (QL)
    - The Clock Class attribute in the Announce messages in PTP is used to carry the SSM QL value
    - Master with the highest Quality Level that is not in a failure condition will be selected
    - In case of Masters with similar QL, the Master with the highest Priority is selected.
  - Priority
    - Each master has a priority value that is locally maintained in the Telecom slave.
  - Packet Timing Signal Fail (PTSF)
    - PTSF-lossSync, PTSF-lossAnnounce, PTSF-unusable
- G.8265.1 introduces the concept of a Telecom Slave
  - Consists of one or multiple PTP slave-only ordinary clock instances



International  
Telecommunication  
Union

# ITU-T TIME/PHASE PROFILE G.8275.1

# G.8275.1- ITU-T Time/Phase Profile IEEE-1588 with full support from Network

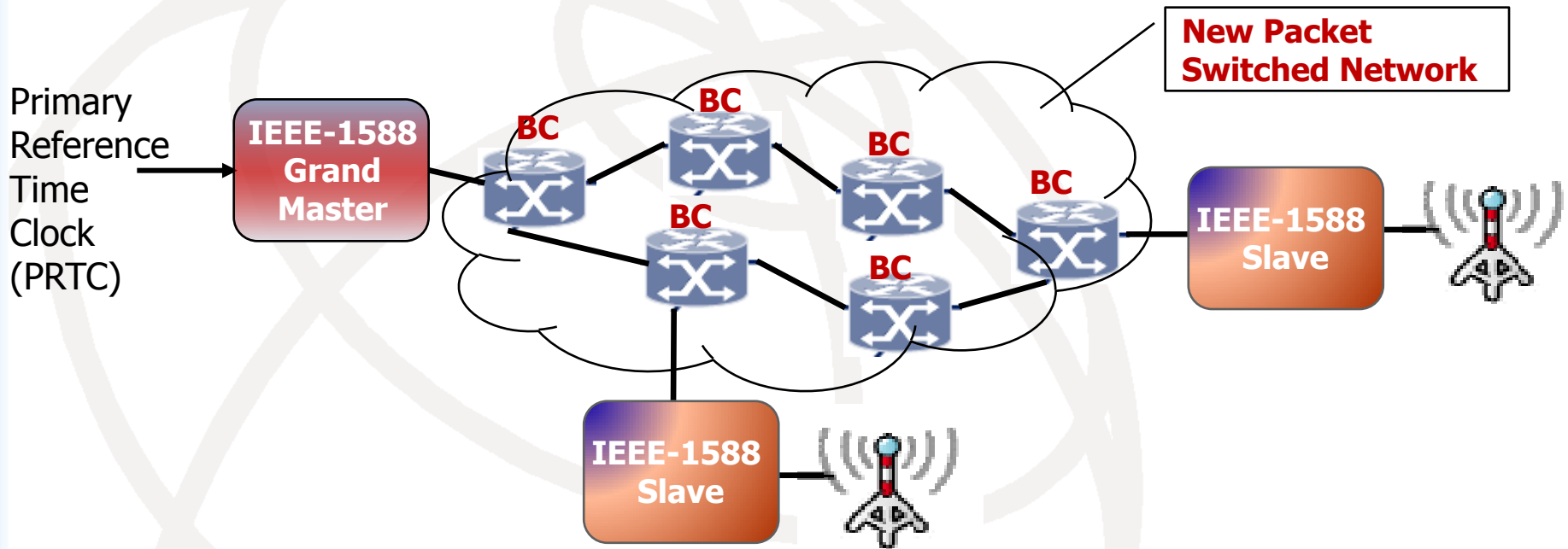

- Boundary Clocks (BCs) and Transparent Clocks (TCs) can be used to overcome the performance issue
- Synchronous Ethernet is used in conjunction with BC for the first version of the profile
- The work on TC is on-going at ITU
- ITU-T have consented several recommendations (G.827x) to address time and phase applications

# G.8271.1 Architecture

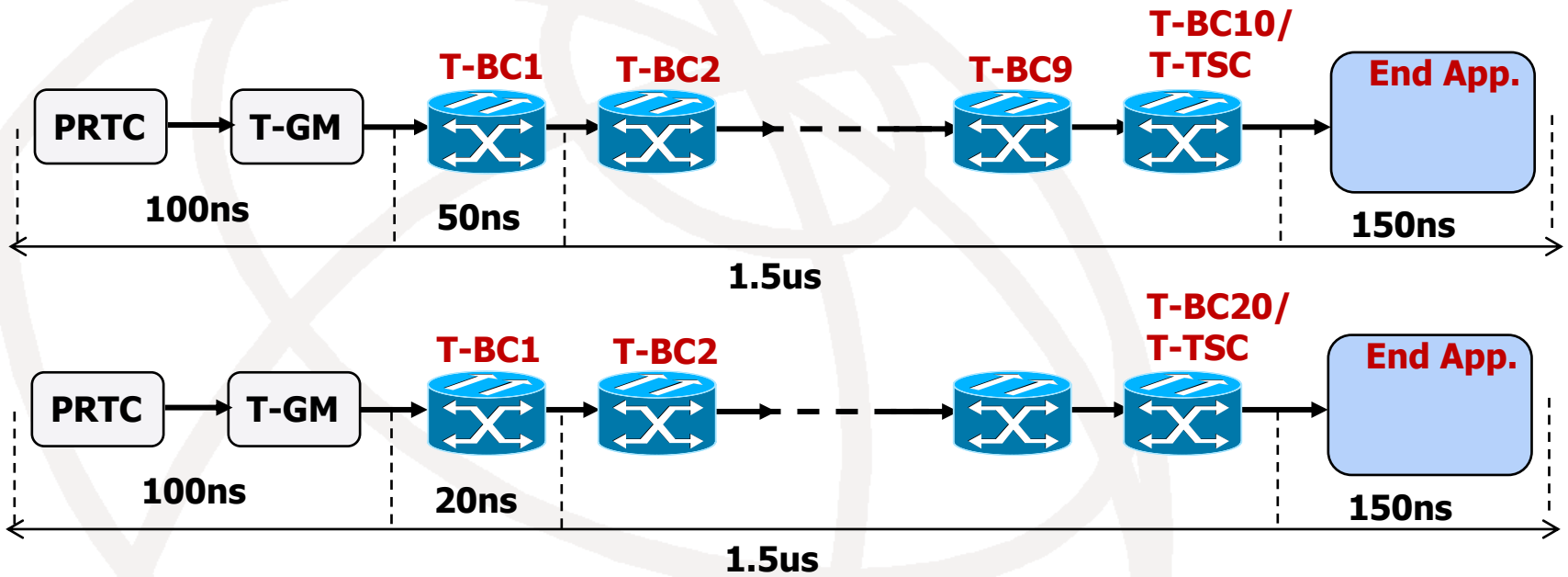

- G.8273.2 defines the T-BC and T-TSC specifications
- The network limit of 1.5us also accounts for other sources of noise (e.g. holdover, link asymmetries, syncE rearrangements)
- Two classes of Telecom Boundary Clock (T-BC) and Telecom Time Slave Clock (T-TSC)

T-BC Constant TE Classes	Maximum Constant Time Error (ns)
A	50
B	20

G.8273.2/Table 1 – T-BC Constant Time Error Classes

PRTC = Primary Reference Time Clocks  
T-GM = Telecom Grand Master

## G.8275.1 PTP Options and Configurable Attributes

- Two types of Ordinary clocks: T-GM (Telecom Grand master, master clock only) and T-TSC (Telecom Slave clock, Slave-Only Ordinary Clock)
- Boundary clock will be used on the first profile, transparent clocks will be added in future version
- One-step and two-step clocks are allowed
- PTP mappings
  - The default mapping for the Time/phase profile is agreed to be IEEE1588-2008 annex F - Transport of PTP over Ethernet
  - IEEE1588-2008 annex D - Transport of PTP over User Datagram Protocol over Internet Protocol Version 4 is for further study
  - IEEE1588-2008 annex E - Transport of PTP over User Datagram Protocol over Internet Protocol Version 6 is for further study
- Multicast mode
  - For the Ethernet mapping, both the forwardable multicast address 01-1B-19-00-00-00 and the non-forwardable multicast address 01-80-C2-00-00-0E must be used for all PTP messages'
  - The default Ethernet multicast address to be used depends on the operator
- PTP Message types and rates
  - Sync message, Follow-up, Announce, Delay\_Request, and Delay\_Response
  - Fixed packet rate of 16 packets per second for Sync, Delay\_Req and Delay\_Resp messages for the case where physical layer frequency support (e.g. Synchronous Ethernet) is used
  - Fixed packet rate of 8 packets per second for Announce message

# G.8275.1 - Alternate BMCA

- The alternate BMCA in G.8275.1 is based on the default BMCA specified in IEEE 1588
  - It has provisions to allow a manual network planning
- The alternate BMCA allows
  - Multiple Grand Masters
  - Per-port Boolean attribute notSlave.
    - notSlave is TRUE -> the port is never placed in the SLAVE state
    - notSlave is FALSE -> the port can be placed in the SLAVE state
  - Per-port attribute localPriority to be used as a tie-breaker in the dataset comparison algorithm
    - Using different values than their default value allows building manually the synchronization network topology
  - The clock attribute priority1 is static
  - The clock attribute priority2 is configurable
  - the clock attributes clockAccuracy and offsetScaledLogVariance must be set to specific values defined in G.8275.1



International  
Telecommunication  
Union

# ITU-T TIME/PHASE PROFILE G.8275.2

## G.8275.2- ITU-T Time/Phase Profile IEEE-1588 without support from Network

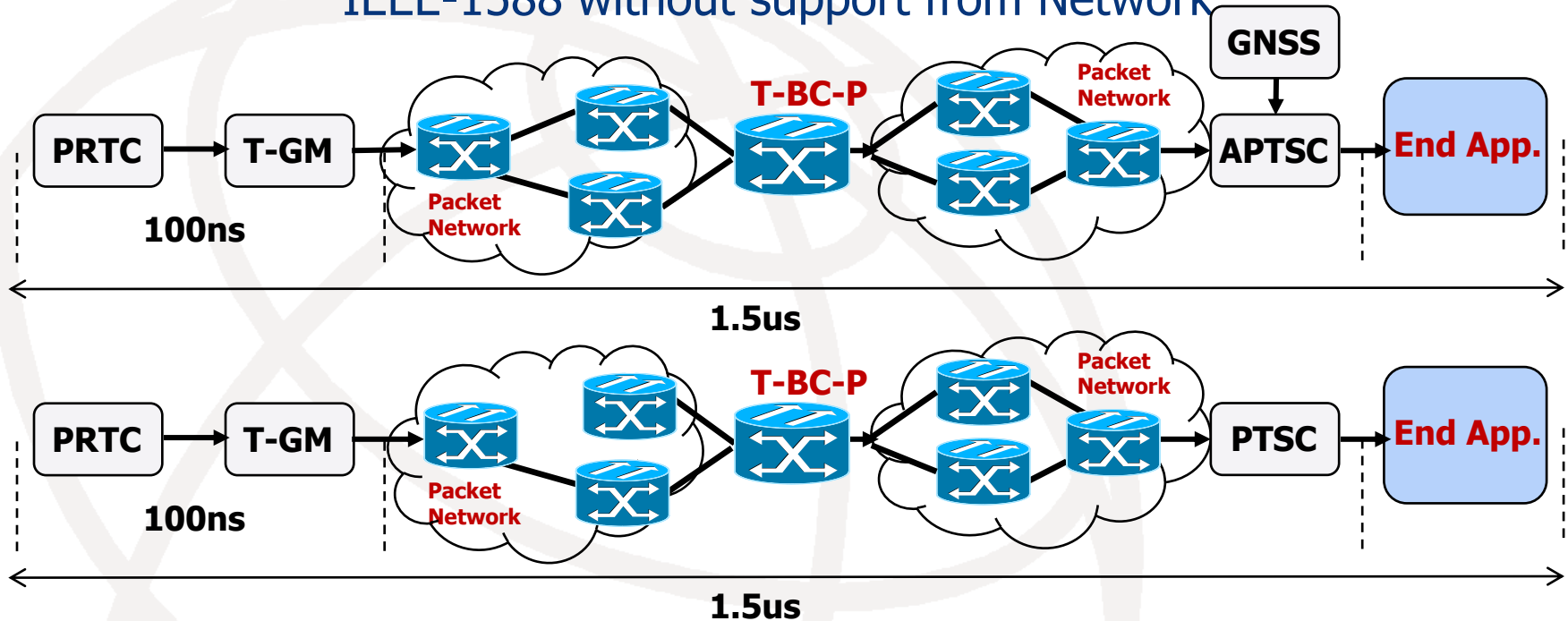

- ITU-T will first focus on the Assisted Partial Timing Support (APTS) profile where GNSS is co-located with the end application
  - The local GNSS (e.g. GPS) can be used to measure the asymmetry of the network
  - PTP is used as a backup for GNSS failures
- For the Partial Timing support without the GNSS co-located with the end application, how many nodes in the network?
  - Discussions are on-going at ITU regarding the network topology/architecture

GNSS= Global Navigation Satellite System



# IEEE 1588

# IEEE 1588

- IEEE Std 1588™-2002 (version 1) was published November 8, 2002
  - Defines a Precision Time Protocol (PTP), therefore is also referenced as PTP
  - IEEE 1588 synchronizes real-time clocks in the nodes of a distributed networked system.
- IEEE Std 1588™-2008 (version 2) was approved March 27, 2008 and published July 24, 2008
  - It is available for purchase from the IEEE web site
    - <http://www.ieee.org/web/standards/home/index.html>
- Applications
  - Industrial Automation, Test and Measurement, Military, Power generation and distribution, Consumer electronics, and Telecommunications

# IEEE 1588 Revision

- Working Group to revise IEEE 1588 was formed
- Project Authorization Request (PAR) was approved in June 2013
  - Correct known technical and editorial errors
  - Precision and accuracy improvements
  - SNMP-compliant MIB
  - Security
  - Clarification of layering, interfaces, and protocol of the standard
  - **Backwards compatibility with version 2 is a must**
- Five sub committees have been created to focus on several aspects of the technical work
  - Architecture
  - High Accuracy
  - Upkeep
  - Management
  - Security
- Each sub committee meets once or twice a month via conference call
  - A charter and a requirements document have been created for each sub-committee

# **NORTH AMERICA STANDARDS (SONET/PDH)**

# North America Synchronization Hierarchy

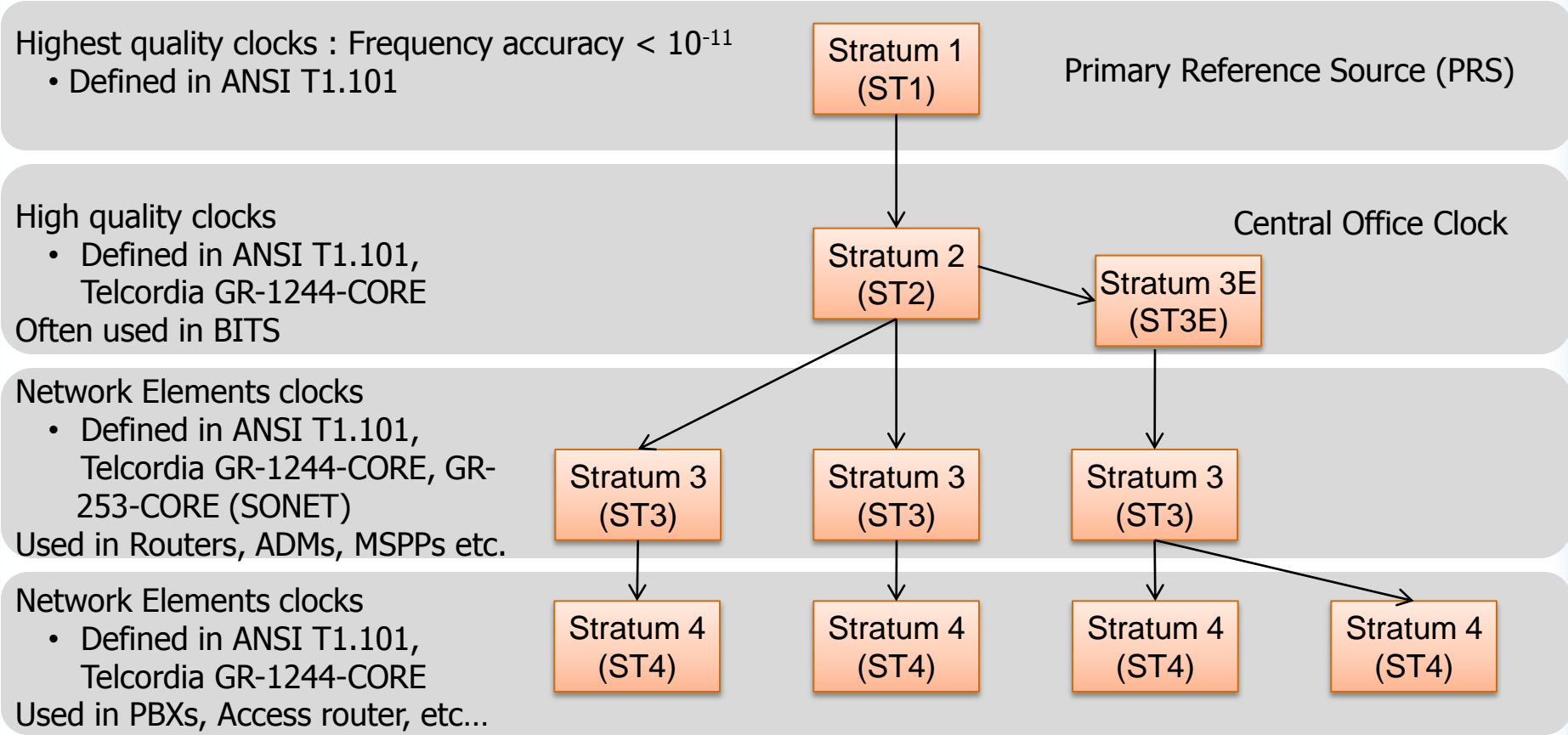

BITS – Building Integrated Timing Supply

# Stratum Levels

- The stratum levels are associated with the clock performance parameters
  - Free-run accuracy
  - Holdover
  - Output phase transients
  - Pull-in and Hold-in
  - Filtering (PLL Bandwidth)
- The performance parameters for the various levels have been established to assure that synchronization can be transmitted through the network from the most accurate clocks (ST1), through intermediate clocks (ST2, ST3), to the least accurate clocks (ST4)
- The use of payload pointers in SONET necessitates the use of different filtering and wander generation criteria for stratum clocks deployed in NEs that support SONET interfaces
  - The reason for defining clocks in GR-253-CORE
- GR-1244 states “Stratum 3E requirements on filtering of wander and holdover are significantly tighter than the stratum 3 requirements. GR-436-CORE recommends that stratum 3E clocks be the minimum clocks used in BITS applications. In addition, it is recommended that stratum 3E or higher quality clocks not be used in any NE other than a BITS (e.g., it is recommended that transport NEs use stratum 3 or lower quality clocks).

# GR-1244-CORE vs. GR-253-CORE

- GR-1244-CORE provides synchronization related criteria from the equipment point of view
  - It describes clocks that may be stand-alone synchronization sources [e.g., Primary Reference Sources (PRs)], embedded in Network Elements (NEs) whose specific function is to distribute synchronization from a source to other Nes (e.g.; digital switches, Digital Cross-connect Systems (DCSs) or Add-Drop Multiplexers (ADMs)).
- GR-253-CORE contains the Synchronous Optical Network (SONET) specifications
  - GR-253-CORE defines all the aspects of a SONET equipment including clocks to be used in the SONET equipments
  - If the clock requirements are the same as GR-1244-CORE then it refers back to GR-1244-CORE
  - If the clock requirements need to be different from GR-1244-CORE then it is specified in GR-253-CORE



# **ITU-T STANDARDS (SDH/PDH)**



# ITU-T Clock Hierarchy (G.803)

Highest quality clocks : Frequency accuracy  $< 10^{-11}$

- Defined in ITU-T recommendation G.811

Equipment slave clocks

- Defined in ITU-T recommendation G.813

Used in Routers, ADMs, MSPPs etc.

SSU - High quality clocks

- Defined in ITU-T recommendation G.812

SDH Synchronization chain is defined in ITU-T Recommendation G.803

- Consists of 1 PRC followed by 20 SECs, followed by SSU
- The maximum number of SSUs is 10
- Maximum number of clocks is 60

PRC – Primary Reference Clock  
 SSU - Synchronization Supply Unit  
 SEC - SDH Equipment Clock

TUPP – Tributary Payload Processor

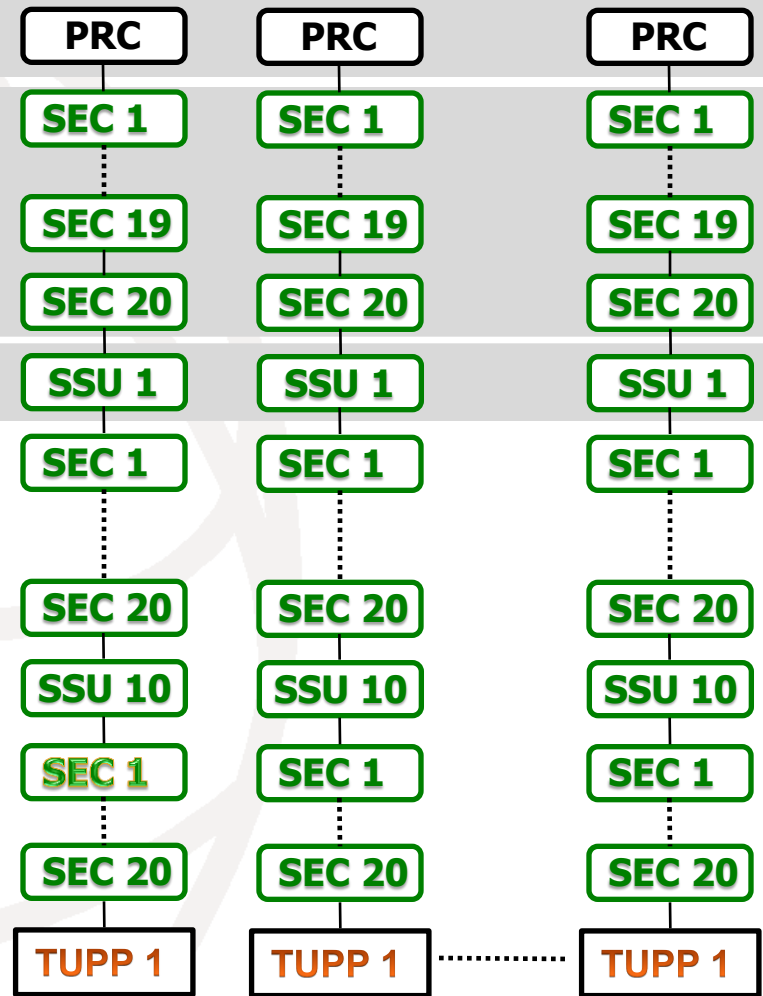

# Clock Types

North America Clock	ST1 (PRS)	ST2	Not Defined	TNC	ST3E	Not Defined	ST3	Not Defined	SMC	ST4E	ST4
ITU-T Clock	PRC (G.811)	Type II (G.812)	Type I (G.812)	Type V (G.812)	Type III (G.812)	Type VI (G.812)	Type IV (G.812) EEC-option 2 (G.8262)	Option 1 (G.813) EEC-option 1 (G.8262)	Option 2 (G.813)	Not Defined	Not Defined
Accuracy	$\pm 1 \times 10^{-11}$	$\pm 1.6 \times 10^{-8}$	Not defined	$\pm 1 \times 10^{-7}$ Not defined for ITU	$\pm 4.6 \times 10^{-6}$	Not defined	$\pm 4.6 \times 10^{-6}$	$\pm 4.6 \times 10^{-6}$	$\pm 20 \times 10^{-6}$	$\pm 32 \times 10^{-6}$	$\pm 32 \times 10^{-6}$
Holdover	Not defined	$\pm 1 \times 10^{-10}$	$2.7 \times 10^{-9}$	$\pm 1.5 \times 10^{-9}$	$\pm 1.2 \times 10^{-8}$	$3 \times 10^{-8}$	$3.7 \times 10^{-7}$	$2 \times 10^{-6}$	$4.6 \times 10^{-6}$	Not defined	Not defined
Pull-in	Not defined	$\pm 1.6 \times 10^{-8}$	$\pm 1 \times 10^{-8}$	$\pm 1 \times 10^{-7}$ Not defined for ITU	$\pm 4.6 \times 10^{-6}$	Not defined	$\pm 4.6 \times 10^{-6}$	$\pm 4.6 \times 10^{-6}$	$\pm 20 \times 10^{-6}$	$\pm 32 \times 10^{-6}$	$\pm 32 \times 10^{-6}$
BW	Not defined	0.001Hz	0.003Hz	0.1 Hz	0.001 Hz	0.1 Hz	3 Hz 0.1 Hz (SONET)	1 – 10 Hz	0.1 Hz	Not defined	Not defined
Rearrange ment MTIE	Not defined	$\leq 150$ ns OT=5000 (ST2) OT=280 (ITU)	$\leq 240$ n OT=100000s	$\leq 1\mu$ OT=64s (TNC) OT=10000s (ITU)	$\leq 150$ ns OT=64s (ST3E) OT=280s (ITU)	$\leq 1\mu$ s OT=280s	$\leq 1\mu\sigma$ OT=64s (ST3) OT=280s (G.812) OT=10S (G.8262)	$\leq 1\mu$ s OT=15s	$\leq 1\mu$ s OT=280s (SMC) OT=10s (ITU)	$\leq 1\mu$ s OT=64s	Not defined

ST = Stratum  
 SMC = SONET Minimum Clock  
 BW = Bandwidth  
 MTIE = Maximum Time Interval Error  
 OT=Observation Time

# REFERENCES

# North American Published Standards

- GR-253-CORE - Telcordia Technologies Generic Requirements - Issue 5, October 2009
- GR-1244-CORE - Telcordia Technologies Generic Requirements - Issue 4, October 2009
- ATIS-0900101.2006 - T1.101 - Synchronization Interface Standard

# ITU-T Published Recommendations (PDH/SDH)

- All ITU-T Published Recommendations can be downloaded from:  
<http://www.itu.int/rec/T-REC-G/e>
- ITU-T Recommendation G.803, Architecture of transport networks based on the synchronous digital hierarchy (SDH).
- ITU T Recommendation G.810, Definitions and terminology for synchronization networks.
- ITU T Recommendation G.811, Timing characteristics of primary reference clocks.
- ITU T Recommendation G.812, Timing requirements of slave clocks suitable for use as node clocks in synchronization networks.
- ITU T Recommendation G.813, Timing characteristics of SDH equipment slave clocks (SEC).
- ITU-T Recommendation G.823, The control of jitter and wander within digital networks which are based on the 2048 kbit/s hierarchy
- ITU-T Recommendation G.824, The control of jitter and wander within digital networks which are based on the 1544 kbit/s hierarchy
- Recommendation ITU-T G.825, The control of jitter and wander within digital networks which are based on the synchronous digital hierarchy (SDH)

# ITU-T Published Recommendations (Packet Sync - Frequency)

- All ITU-T Published Recommendations can be downloaded from:  
<http://www.itu.int/rec/T-REC-G/e>
- ITU T Recommendation G.8261, Timing and synchronization aspects in packet networks.
- ITU T Recommendation G.8262, Timing characteristics of Synchronous Ethernet Equipment slave clock (EEC).
- ITU T Recommendation G.8264, Distribution of timing through packet networks
- Recommendation ITU-T G.8261.1, Packet Delay Variation Network Limits applicable to Packet Based Methods (Frequency Synchronization).
- Recommendation ITU-T G.8263, Timing Characteristics of Packet based Equipment Clocks
- ITU-T Recommendation G.8265, Architecture and requirements for packet based frequency delivery
- ITU-T Recommendation G.8265.1, Precision time protocol telecom profile for frequency synchronization
- ITU-T Recommendation G.8260, Definitions and terminology for synchronization in packet networks

## ITU-T Rec. (Packet Sync – Frequency) – work in progress

- ITU T Recommendation G.8266 , Timing characteristics of packet master clock for frequency synchronization
- ITU T Recommendation G.8262.1, Timing characteristics of an enhanced synchronous Ethernet equipment slave clock (EEC)

# ITU-T Consented Recommendations (Packet Sync – Phase/Time)

- All ITU-T Published Recommendations can be downloaded from:  
<http://www.itu.int/rec/T-REC-G/e>
- ITU T Recommendation G.8271, Time and phase synchronization aspects of packet networks
- ITU T Recommendation G.8272, Timing characteristics of Primary reference time clock
- ITU T Recommendation G.8271.1, Network limits for time synchronization in Packet networks
- ITU T Recommendation G.8272, Primary Reference Timing Clock (PRTC) specification
- ITU T Recommendation G.8273, Framework of phase and time clocks
- ITU T Recommendation G.8273.2 , Timing characteristics of telecom boundary clocks and telecom time slave clocks
- ITU T Recommendation G.8275, Architecture and requirements for packet-based time and phase delivery
- ITU T Recommendation G.8275.1, Precision time protocol telecom profile for phase/time synchronization with full timing support from the network



# ITU-T Rec. (Packet Sync – Phase/Time) – work in progress

- ITU T Recommendation G.8271.2, Network limits for time synchronization in packet networks with partial timing support
- ITU T Recommendation G.8272.1, Timing characteristics of enhanced primary reference time clock
- ITU T Recommendation G.8273.1 , Timing characteristics of Telecom Grandmaster clocks
- ITU T Recommendation G.8273.3 , Timing characteristics of telecom transparent clocks
- ITU T Recommendation G.8273.4 , Timing characteristics of assisted partial timing support slave clocks (APTSC)
- ITU T Recommendation G.8275.2 , Precision time Protocol Telecom Profile for time/phase synchronization with partial timing support from the network
- ITU T G.Sup, Simulations of transport of time over packet networks

**QUESTIONS???**  
**THANK YOU!!!!!!**